



Website Design Application Form

The following three part questionnaire will help us estimate the timeline and cost of your new website. To give you the best quality web design directly depends on us clearly understanding your project vision and goals, so it's important that you answer the questions thoroughly.

This is a long form and may require clarification at some point. We are ready to assist so do not hesitate to ask - via email to support@oceaniawebhosting.com.au or phone call to 1300 301 990.

Part I – Basic Website Information

CONTACT INFORMATION	
Contact Person	
Position	
Best Phone	
Best Email	
Company Name	
Address	
City	
State / Postcode	
Country	

Please note that our website design costs will most likely fall into one of the categories described in our website's Web Site Design Page - see www.oceaniawebhosting.com.au/website-design so please keep in mind your budget allocation. Applicants who qualify for our 24 month payment option can look forward to a very affordable and professional website – so why not ask for details?

Domain Name Information

❖ Do you already have a domain name? No Yes:

❖ If you have multiple domains, please list them all below, and specify which one will be the default:

Additional Domain Names to be used	default y/n

If you do not have a domain name please list the top three choices for your domain name. Pls indicate the domain name with extension (.com/.com.au):

	Name	Extension
a.	www.	.com /.com.au
b.		
c.		

Hosting

To have your website visible on the Internet, it needs to be “hosted” on a web server. Websites we create can be hosted with us (optimal), or with any competent service provider. Our hosting clients automatically receive discounted development fees.

If your website is already hosted elsewhere, and you intend to transfer it to our hosting service, we will need access details for your website, and access details for your domain name. This transfer will have to be coordinated with you and previous provider, to ensure no information is damaged or lost.

❖ Would you like us to provide the hosting service to you? Yes No

❖ Will you use our server as the email server for your domain? Yes No

❖ Will you require additional DNS records (if unsure, answer no)? Yes No

- ❖ Please indicate any additional hosting requirements, such as large email volume, large number of required email accounts, large expected bandwidth usage, large expected data transfers, additional ftp accounts, etc.

Design Preferences

In this section we would like to find out more about your design preferences. The sites you list below will help us when developing general look and feel for your website.

- ❖ Please list addresses for websites you like and list the reasons why (specify elements / features you particularly like):

http://

Reasons:

http://

Reasons:

http://

Reasons:

- ❖ Please list addresses for websites you dislike and list the reasons why (specify elements / features you particularly dislike):

http://

Reasons:

http://

Reasons:

http://

Reasons:

- ❖ Please list addresses for websites of your direct competition, if applicable:

http://

http://

- ❖ Which colours would you like to dominate on your website?

- ❖ Would you like your site light or dark?

Note that if you do not have company colours, you do not have to be very specific. Also – note that the colours look different on a computer screen than on print material. They also vary from monitor to monitor, depending on their quality, size and settings.

Logo

Normally the company logo appears on the website. You might already have one, or you might want to have one designed at this time.

It is important to understand that website graphics are quite different to print graphics. Print graphics require much higher quality. Any photographs for your website need to be in high resolution and as large as possible. We cannot “up-size” small images. Illustrations need to be in “vector” format, which enables resizing without any loss in quality.

If you need the logo just for the website, it will be a part of your website design. However, if you need it for other purposes, it will be a separate project, which should be finalized before the website work begins.

- ❖ Does your company have a logo? Yes No
- ❖ If yes, can you provide the logo in an electronic format? Yes No
- ❖ If no, would you like us to design a logo for you? Yes No

- ❖ In case we design the logo for you, would it be used for purposes other than the website (e.g. print material, T-shirts, banners, posters, etc.)? Yes No

If Yes, Please specify the additional use:

Content, Copy-Writing, Editing and Translation Services

Websites usually contain graphics (photographs, illustrations) and written content. Before the website development project starts, you will need to gather and provide us with all the content you wish to have placed on the website. It greatly assists to have all proposed content written prior to start. This will also help us to come up with the best structure and the ways to organize your content.

- ❖ Please enter your proposed menu items on the template below the following example. Include as many as you need - there is no need to complete the entire sheet.

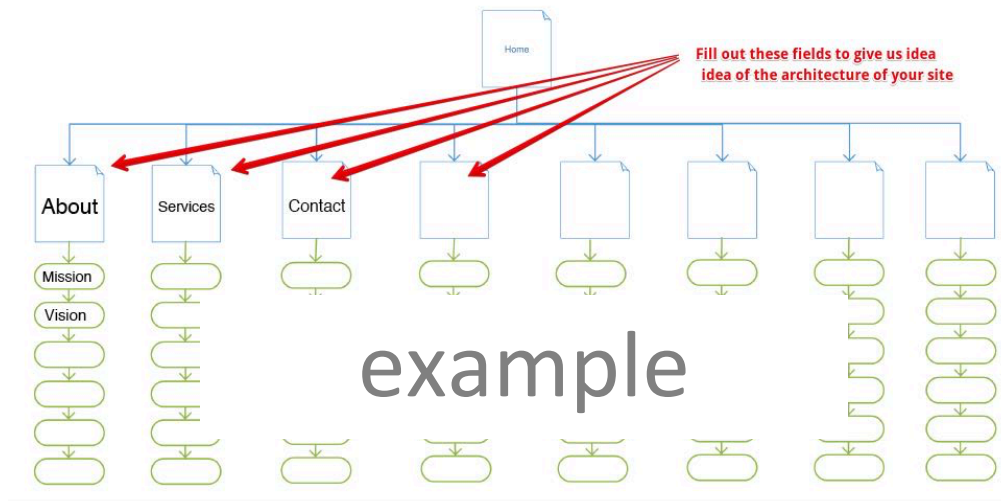

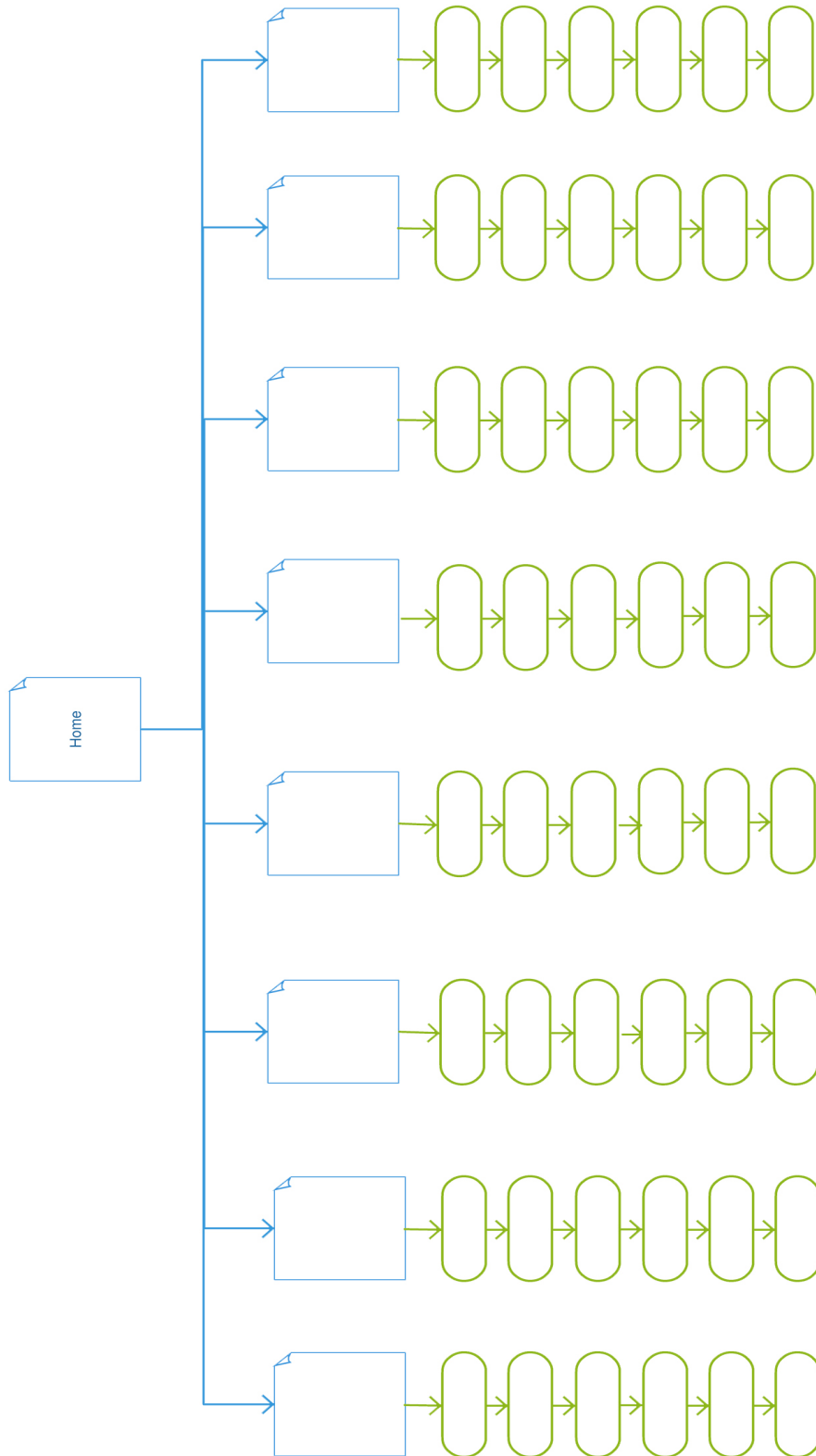

- ❖ Will you need a photographer to visit your location (to take pictures of your facility, staff or products)? Yes No

- ❖ Would you like your content to be edited? Yes No

- ❖ Would you like your content to be written by a copy writer? Yes No

- ❖ Do you have a need to have your website in multiple languages? Yes No

If 'Yes', please specify the languages:

Part II – Functionality

Most websites exist to showcase and/or sell products and/or services, help the owner communicate with the client or membership base, and provide information about the company or organization, or a certain topic. In this section we will cover the most common website features. If the features you have in mind are not covered, you will have an opportunity to add them at the end of the form. If any of the sections is not applicable to your project, leave them blank.

Content Management

Content Management System (CMS) enables you to add / edit / delete and organize pages on your website after the design is launched. If your website has e-commerce functionality, the display and management of products is covered later in this questionnaire. Please let us know which of the following content management features you would like on your website. We typically use Wordpress CMS as the current web standard CMS.

- ❖ Will you need CMS functionality? Like Wordpress for example Yes No

- ❖ Will you have any specifically structured content, such as blog, events or projects? For example, a xxwsxx blog will have a title, subtitle, date, summary and article. Yes No

Please specify:

E-Commerce / Product Catalog

This covers any product display functionality, whether or not the products are being sold through the website (some businesses use websites for display only). The standard way of displaying products is by grouping them into product categories / subcategories. Each product can have variants, options, sale price and pictures. Additionally, products can have multiple prices (e.g. wholesale / retail). If your site will have a shopping cart, it can calculate shipping charges and accept payments.

- ❖ How many products will be displayed on your site (approximately)?

- ❖ Approximately, in how many main categories will those products be grouped?

- ❖ Will you require shopping cart functionality? Yes No

- ❖ Which shipping provider will you be using?

Aust Post Custom Calculations Other (please specify) _____

- ❖ Which payment method(s) would you like to use?

Credit card through Merchant Facility

Credit card through PayPal PRO

PayPal website payments

Self-processing (order comes in an encrypted email message)

Other (please specify) _____

- ❖ Will you use the website to track your inventory quantities?

For example, if a product is sold out, it is no longer in stock, and cannot be ordered through the website until the stock is replenished.

Yes No

- ❖ Will your products have multiple price levels (wholesale / retail)? Yes No

 - ❖ Will you require an order management system (OMS) (allows access to order history, order search and communicating events related to a particular order to the client)? Without an OMS, you will still be receiving copies of orders in your email. Yes No

 - ❖ Will you require data entry service? Initially, only a sample of products is needed to get the website started, but we can provide you with the data entry service for your entire inventory.
Yes No

 - ❖ Please provide three sample descriptions of your products. Try to use the most complex ones. Indicate the product ALL details (size, colour, price, sale price, stock number, description, category, manufacturer etc). These samples will be used to create the interface which will work the best for your products. Please attach a separate sheet.
-

- ❖ Are there any specifics we need to know about e-commerce solution for your site? Please describe:

User Management

User management usually means visitors can create an account connected to the site, which gives them access to “restricted” content, store their preferences, see wholesale prices, use certain features reserved only for registered users, etc. If you have a need for such a system, please describe it in detail in the area below. Describe which information will be needed to create an account, which credentials will be required to log into an account, will the administrator intervention be required before an account becomes active, what benefits will a registered user have, are there multiple user levels / groups, etc.

Mailing List(s)

Mailing list functionality allows your site visitors to sign up for a newsletter. The website administrator can also add emails to the list, and sort them into groups. Mailings can be composed and sent to particular group(s) or the entire list. As part of this setup we will create one email template which can be used for creating new messages.

- ❖ Will you need the mailing list feature? Yes No

- ❖ Will you need additional message templates (e.g. seasonal), and if so, how many?
Yes No _____

- ❖ Are there any specifics we need to know pertaining to mailing lists functionality for your site?
Please describe:

Target Audience and Accessibility

For a website to be successful, it is important to clearly identify the target market segment. Sometimes a web project might require adhering to specific accessibility and security guidelines and laws. While we will create your website in a way that is usable by large majority of people using relatively modern technologies and tools, there could be a need for additional accessibility and security considerations. If this is the case, please provide the details below.

Search Engine Optimization

At this time the most relevant search engine and industry standard setter is Google. This is why your website will be optimized according to current Google guidelines. Please list below up to five key phrases / keywords for which you think your website will be relevant. In other words, which words or phrases should a person type in a search engine to find your website.

Other Functionality

We covered the most common website features in this form. However, if you require any other functionality for your website, please describe it in detail here. Please provide as much information, data samples, existing website examples etc. as you can.

Part III – Project goals and expectations

The success of any project depends on clearly established goals and reasonable / measurable expectations. Your responses to these five questions are crucial in accurate assessment of your needs. Please include as many details of your expectations as possible, including concrete numbers and time line (pertaining to the website after its launching).

Please clearly explain:

❖ Why do you want a website?

❖ What would you identify as the single, most important purpose of your website?

❖ What do you expect this website will do for your business?

❖ How do you intend to market your website?

❖ What region(s) do you serve (e.g. Sydney, Australia, North America etc)

Thank you for taking the time to fill in this questionnaire as it will ensure that you get the very best design service from us.

Please email it to support@oceaniawebhosting.com.au or fax to (02) 9475 0070. We will contact you if we have any additional questions and get back to you with a quotation shortly.